

# AP Briquetting Presses

VOTECS

Wood shavings  
Milling shavings  
Sawdust  
Wood dust  
Chips  
Paper  
Styrofoam

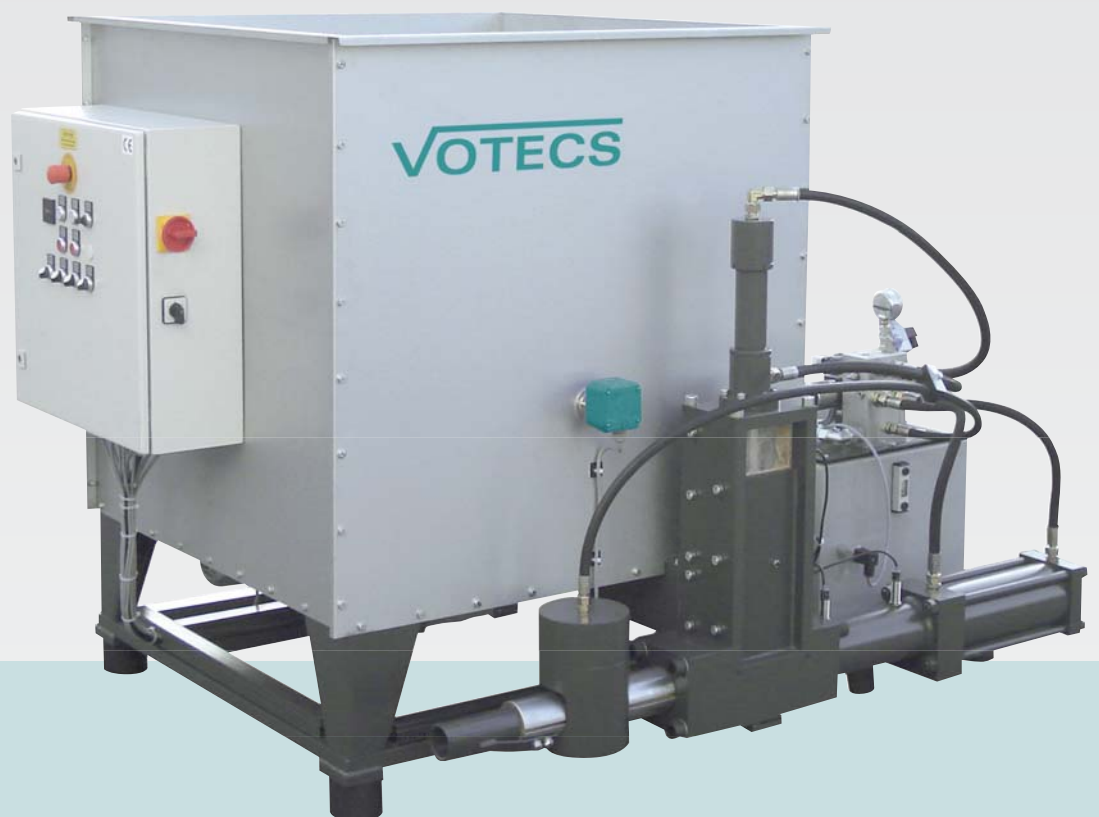

## Compact briquetting presses for volume reduction and heat energy production

Craft enterprises and industrial operations produce wood chips, shavings and saw dust on a daily basis that take up considerable space to store and transport. By contrast, briquettes save space and are easier to transport, and unlike loose materials, present a far lower risk of spontaneous combustion.

Briquetting presses from VOTECS process these very wood chips, shavings etc. into compact briquettes that can be used to produce energy for heating. The briquetting presses are installed as a stand-alone machine or in conjunction with evacuation systems.

The features of the briquettes produced by these machines are a huge reduction in volume for the same high heating value and controllable combustion. The following are the hallmarks of VOTECS briquetting presses:

- ✓ Huge reduction in volume resulting in considerable potential savings in the cost of storage, transport and disposal
- ✓ Burn briquettes for cost effective energy production

### Briquetting – Large volumes made small

The material to be compressed is mixed by a continually turning tube extractor in the container and then fed to the pressing mechanism by a discharge screw conveyor. The loose material is then subsequently pre-compressed. Then by means of pressure from the press cylinder the pre-formed briquette is transformed into its final, highly compacted, form. When the programmed pressure value has been reached the tongs open and the prepared briquette is pushed out.

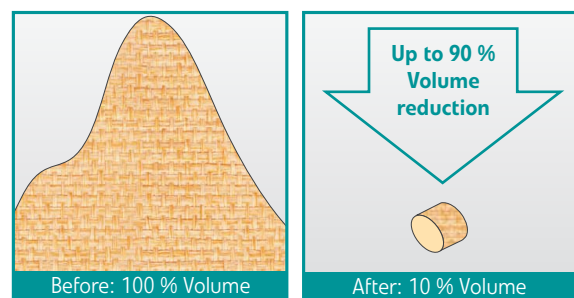

### Thought-out construction

- ✓ Extremely low overall height
- ✓ Left or right hand design
- ✓ Variable container walls
- ✓ Hydraulic system with a separate oil tank
- ✓ Dust sealed pre-compressor
- ✓ End of stroke cushioned cylinder with screw cover
- ✓ Hardened insert casing
- ✓ Solid central main cylinder
- ✓ SPS control
- ✓ Stable ground frame with rubber feet

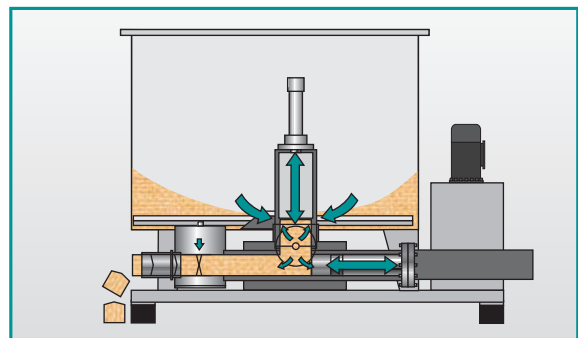
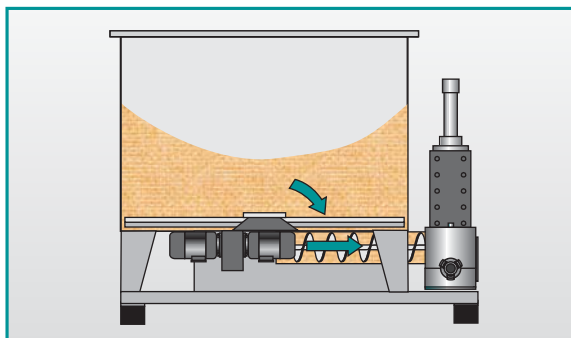
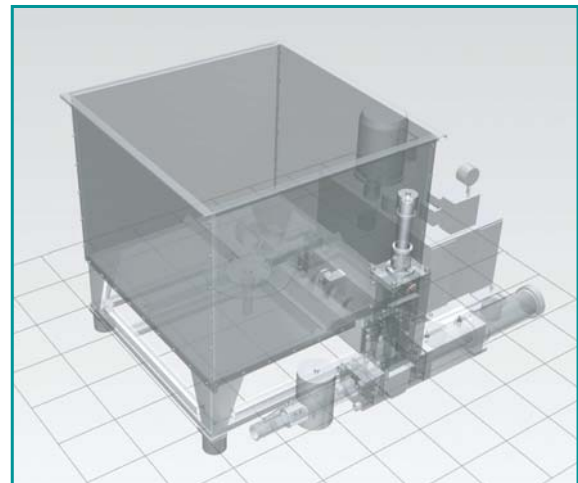

## Sophisticated technology in detail

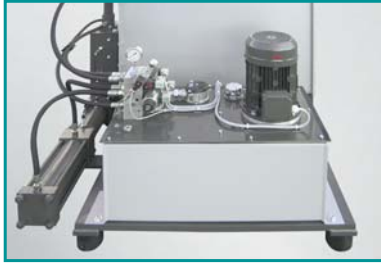

The hydraulic tank is arranged separately. In this way the emerging oil heat is optimally discharged. Good accessibility allows for service friendly maintenance work to be carried out.



The hardened, ground press chamber casing resists wear and tear and can be replaced separately. Thus replacement parts costs are very low.



The continually turning tube extractor mixes the material and sends it to the discharge screw conveyor, which feeds it cyclically to the pressing mechanism.



The intelligent SPS control regulates the switching procedures and has user friendly settings.



With the automatic briquette length feature the length of the briquettes can be constantly maintained even with a variety of materials.



By installing the press on a ground frame it can easily be transported and also allows for greater mobility.

## Delivery programme - Technical Data

Type	Motor	Briquette-Ø	Throughput*	Weight**
AP 440	4 kW	40 mm	40 kg/h	850 kg
AP 555	5,5 kW	50 mm	50 kg/h	870 kg
AP 775	7,5 kW	70 mm	70 kg/h	900 kg
AP 675	7,5 kW	60 mm	100 kg/h	1100 kg
AP 811	11 kW	80 mm	150 kg/h	1800 kg

\*material dependent \*\*equipment dependent

Standard equipment: Pressing mechanism with press, expletive and tong cylinders, press chamber wear bushings (except model AP11110), chrome plated tongs, container with base plate, tube extruder, motor, conveyer channel, discharge screw conveyor, ground frame with oscillating unit, hydraulic tank with pump motor and valve control, switching box including SPS control.

Type	L	W	H	X	Y	S
AP 440	1900	1315	1410	1000	1000	200 mm
AP 555	1900	1315	1410	1000	1000	200 mm
AP 775	1900	1315	1410	1000	1000	200 mm
AP 675	2210	1965	1435	1400	1400	200 mm
AP 811	2210	1965	1435	1400	1400	200 mm

